

### Feature

- Power, a small amount of lubrication.
- The frequency and shock interval are controlled by the solenoid valve.
- Can be used in extreme harsh environments.

### Typical application

- Silos, hoppers, pipes, sieves.
- Eliminate the material inside the container wall, pipe clear.
- Open air, high humidity occasions.

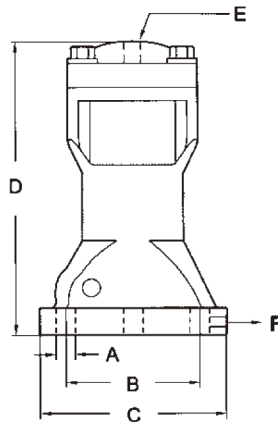

Dimensions

## AH series impact air hammer

With low pressure, strong impact.



### Structure

- Aluminum shell, corrosion resistant, containing special run Grease
- Long life guarantee, to adapt to different applications.

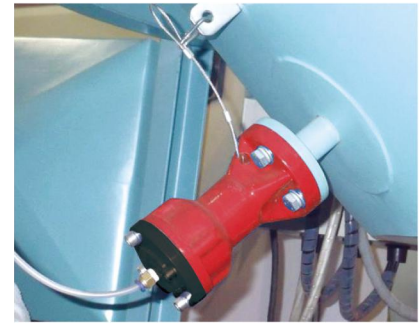

Using case

### Performance parameters

Type	Operating pressure	Air consumption	Impact force	Blow energy	Weight
	MPa	L / B a c k	kg.m/m <sup>2</sup>	N.M	kg
AH-30	0.3~0.7	0.05~0.13	1.9	13	1.25
AH-40	0.3~0.7	0.15~0.37	4.2	22	2.20
AH-60	0.3~0.7	0.33~0.77	11.2	49	5.35
AH-80	0.4~0.6	0.60~1.40	24.2	109	11.20
AH-100	0.5~0.7	0.86~1.55	48.5	220	12.05

### Dimension table (reference)

Type	A	B	C	D	E	F
	mm	mm	mm	mm	G thread	G thread
AH-30	Φ9	Φ67	Φ82	135	G1/4	G1/8
AH-40	Φ11	Φ77	Φ98	175	G1/4	G1/4
AH-60	Φ12.5	Φ110	Φ143	220	G1/4	G1/4
AH-80	Φ17	Φ140	Φ170	275	G3/8	G3/8
AH-100	Φ17	Φ150	Φ195	310	G3/8	G3/8

Note: The data in this table is taken from the Kistler 3-axis dynamometer on a heavy bench. The frequency and force values are reduced when the rigidity is poor.

## AH2 series Relay type air hammer

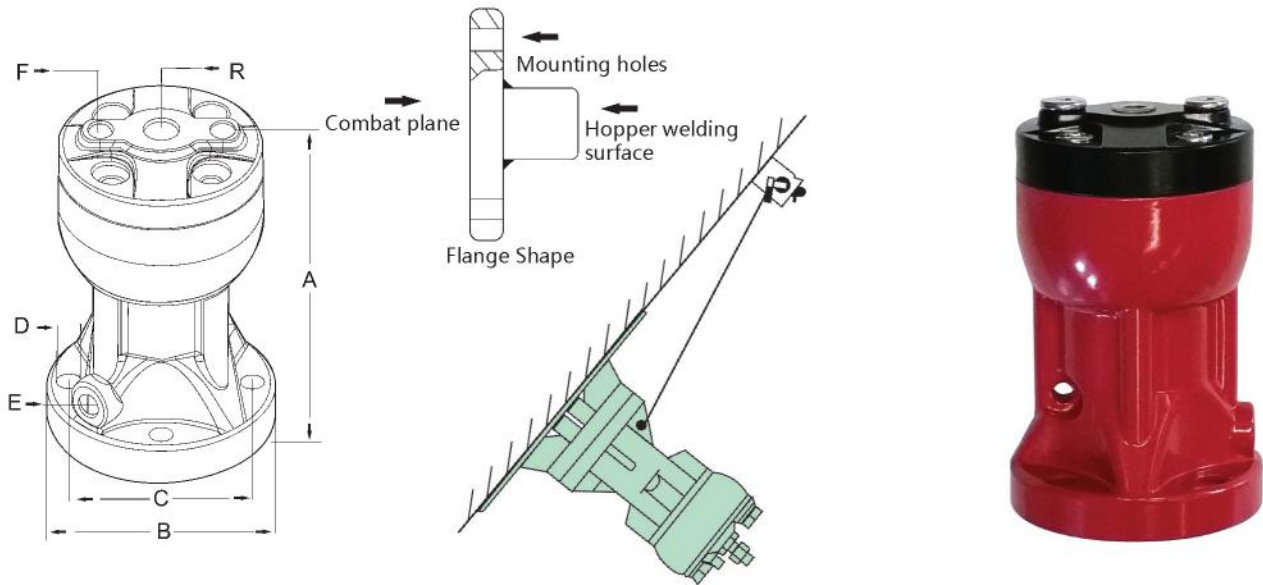

### Product Features

- The second generation of explosion-proof pneumatic hammer (already patented) by tapping intensity is adjusted by adjusting the air pressure. If the intensity is too small to tap Paidu can increase pressure on the contrary knocking down the intensity is too large to use.
- If the customer due to the wrong choice models appeared impact is too strong or insufficient error phenomenon, also can be resolved by adjusting the air force struck a hammer.
- This change may impact the structure of a hammer to ensure selection of convenience. If the installation of the hammer on the relay pipe can be several simultaneous operation, greatly reducing the construction cost.

### Performance parameters

The second generation hammer	Working pressure	Strike period	Air consumption	Blow energy	Impact force		Weight
Type	MPa	Beats / min	L / Back	N·m	Kg·m/S <sup>2</sup>	Corresponding hammer percussion (lbs)	kg
AH30-2	0.3~0.7	1~60	0.06~0.14	5.6~13.2	1.2~1.9	1 以下	1.30
AH40-2	0.3~0.7	1~60	0.16~0.36	9.3~22.5	2.7~4.2	1~1.5	2.20
AH60-2	0.3~0.7	1~60	0.32~0.78	20.8~49.8	7.0~11.2	1.5~3	5.60

### Size Chart

Model	A	B	C	D	E	F	R
	mm	mm	mm	mm	Thread	Relay port	Intake port
AH30-2	132	Φ82	Φ67	Φ9	G1/8	G1/8	G1/4
AH40-2	155	Φ98	Φ75	Φ11	G1/4	G1/8	G1/4
AH60-2	200	Φ145	Φ105	Φ15	G1/4	G1/8	G1/4

## AH2 series Relay type air hammer

### Features

- During body installation work, wear a helmet, safety shoes, belts, carried out in safety equipment.
- When the plate mounting portion comparative table, welding reinforcing plate, because otherwise the shock might cause the installation site of damage.
- Such as welding reinforcing plate, make sure there is no gap between the hopper and the reinforcing plate, and set aside about 10mm exhaust port so as to facilitate the air, so that the impact force is fully conduction. In order to avoid damage in case the hopper, be sure more welding layers.
- To prevent loss, please use the cable and fixed to the body lifting, otherwise they will impact could cause the bolts loose and fall off.
- Bolt the flange when the body and the fixed, please install spring washer up and down, and in strict accordance with the tightening torque tightening and regular inspections.
- Please Front-pipe air filter, if mixed with dust and other junk or may cause undesirable operation.
- Do not use more than necessary when the striking force, as this may cause damage or silo installation site.
- Pummeled the cycle, keep more than one second set, such as 1 second or less may lead to malfunction.
- Make sure the mounting flange against a solid flat surface must, if necessary, please welding reinforcing ribs. ( As shown below)

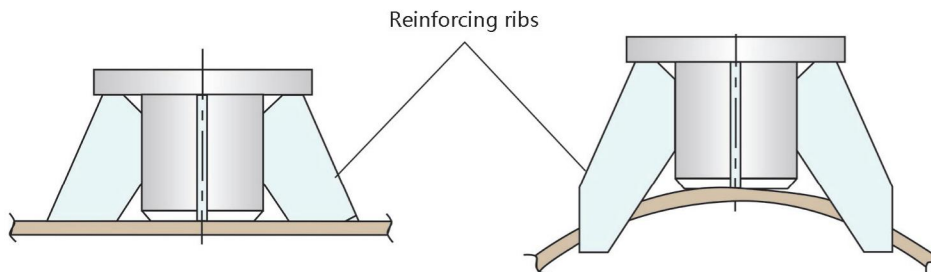
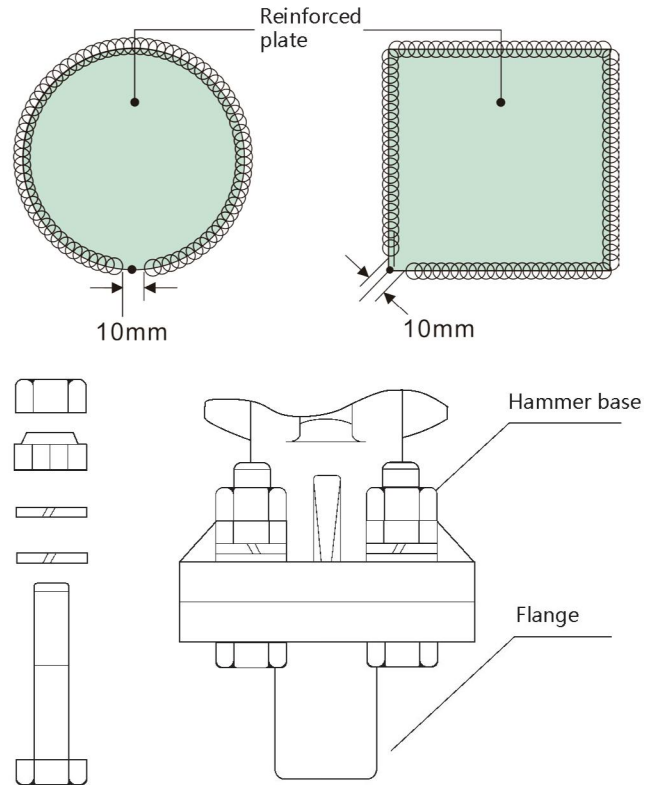

- Pneumatic hammers suitable installation location, can maximize its performance.

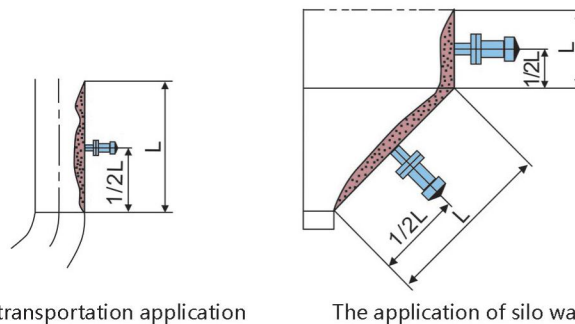
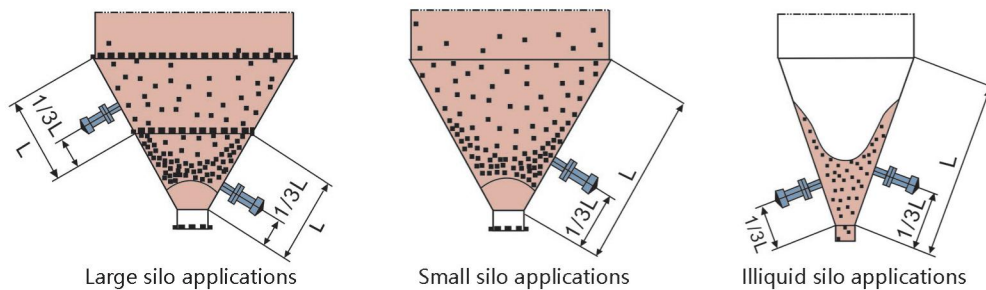



## AH2 series Relay type air hammer

### Relay pipe

The pneumatic hammer can be more than one centralized control, while countering using the relay pipe can achieve this functionality.

- Relay pipe as piping manner multiple hammer directly connected with the relay to the lower trachea coherent inlet connected to control a hammer from the hammer first relay port. However, according to the different methods of operation corresponding maximum number of connected units defined.
- When the relay pipe, compressed air can also cause the relay intratracheal hammer blow. Therefore, the length of the pressure tube and the relay should not exceed a predetermined value.
- When long-distance piping, because the pressure is different, the striking force will vary, may be appropriate to increase the pressure to make up for its full stability, quick exhaust valve can also be set up near the hammer blow to improve its performance.
- When the relay pipe, set air hammer blow interval set at more than 1 second, when the increase in the number of units such as the relay, please set the time interval to extend further.



## Explosion pneumatic hammer dedicated controller

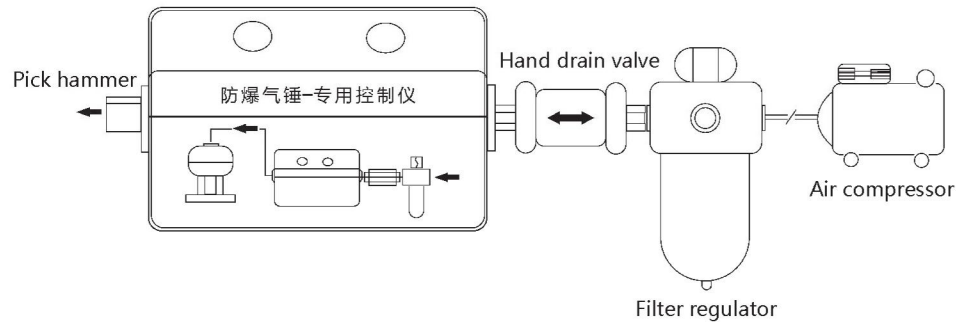
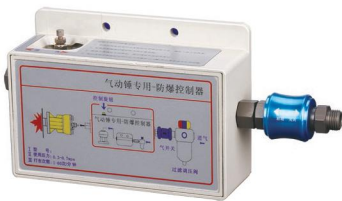

### Features

Pneumatic hammers special explosion-proof controller is a no power, solenoid valves, timers and other control-loop controllers, it can not only control a pneumatic hammer, if the hammer is equipped with a pneumatic tube Relay, you can control more than one operation. In the overall equipment installed in very practical, safe and convenient.

### Performance parameters

Explosion-proof control instrument Model	Environment	Working pressure (MPa)	Fluid temperature (°C)	Number of operations (Times / min)
KLSX-8J	Indoor / outdoor	0.3~0.7	5~55	1~60

### Remarks

- When installing the unit, bolted, to prevent injuries caused by falling.
- When a mobile device, turn off the hand sliding valve controller next to the hammer to prevent accidents caused by abrupt start.
- After work, be sure to close the hand sliding valve controller next, because during the hammer will continue to blow air continuously supplied.
- Unstable pressure, the controller will malfunction, pressure rise – increasing the number of combat air pressure drop – reduce the number of combat, so the air pressure regulating valve installed before the controller, the controller has been conducive to the stability and hammer work.
- To install (electric control) as the supply side of the controller, a timer function, be sure to use the three-way solenoid valve, in order to facilitate the discharge of residual gas.

### Pipe restrictions

Hammer Model	SK30-2	SK40-2	SK60-2
Hammer between the controller	2M	3M	8M

## BVP series piston reciprocating impulse vibrator

### characteristic

BVP series pneumatic hammer vibrator for high-strength aluminum alloy. The main structure consists of impact parts and gas chamber, there is no spring and other wearing parts, and can be any location, any direction of installation. Which uses the compressed air to drive the reciprocating motion of the impingement member in the air chamber to generate a regular vibration, which is excellent in the jamming phenomenon of the bridge. The size of the vibration intensity of vibration can be adjusted by the size of the compressed air pressure and flow to control, and can instantly Qidong and stop working.

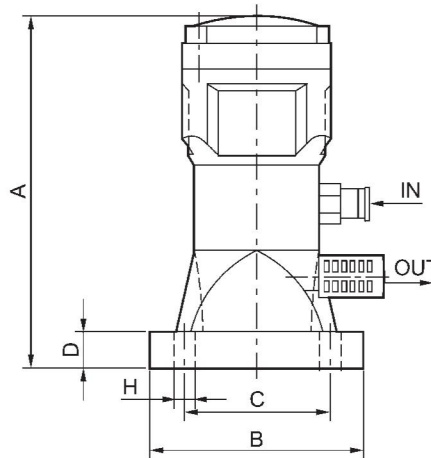

### Size chart

Model	The number of vibrations per minute		Vibration force (N)		Air consumption L / min		A	B	C	D	H	IN	OUT
	0.2 MPa	0.6 MPa	0.2 MPa	0.6 MPa	0.2 MPa	0.6 MPa	mm	mm	mm	mm	mm	Thread	Thread
BVP-40C	174	300	1444	2690	220	270	160	Φ100	Φ75	18	Φ11	G1/4	G1/4
BVP-60C	128	197	1543	3681	260	300	208	Φ140	Φ105	20	Φ15	G1/4	G1/4

### Installation, maintenance and precautions

- Vibrator base Self-welding In the right position, the vibrator is secured to the base with four M10 x30 bolts. Electromagnetic, filters, oil mist, gas source connected.
- Vibrator work to be pure, dry compressed air, so check the filter on a regular basis, there is damage and timely replacement.
- Check the base bolts regularly to prevent the bolts from loosening due to long-term vibration.
- If there is failure to notify the manufacturers of professional maintenance, is strictly prohibited to open the lid to disassemble.

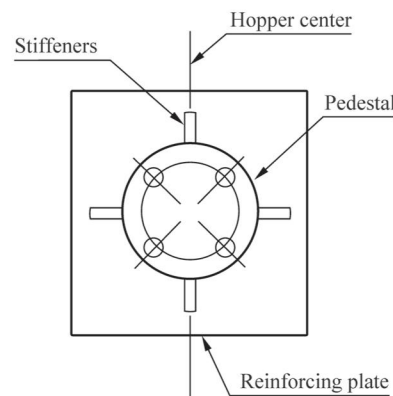
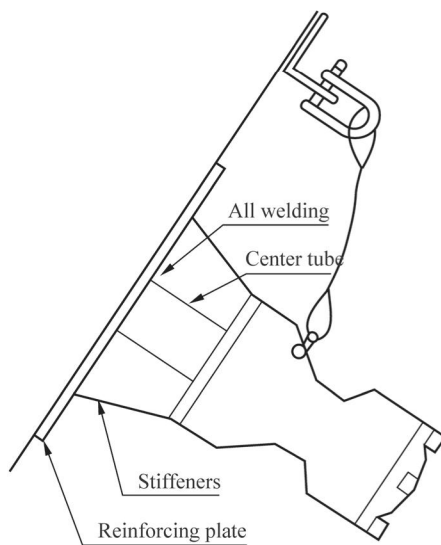

Before installation must be connected to the security link chain hook, so as not to loose screws, falling wounding.